



Boeing B-52G Nuclear Engine Testbed

By: Tony R. Landis



Paths to the Present FLASHBACK



This digital illustration by aerospace artist Aldo Spadoni, of the proposed B-52G Stratofortress with the XNJ140E-1 nuclear powerplant attached to the left side of the bomber, shows how the test configuration may have looked had the nuclear propulsion program continued.

In 1946, The Department of Defense (DoD) initiated a joint project between the Atomic Energy Commission (AEC) and the Air Force known as the Aircraft Nuclear Propulsion (ANP) Program. Based on requirements established by the DoD, the ANP program, known also as the Manned Aircraft Nuclear Propulsion Program, was to develop a nuclear-powered airplane for military purposes. The reactor and related shielding were the responsibility of the AEC while the Air Force was responsible for the airframe, turbomachinery and auxiliary components.

The reason for pursuing the ANP program was to provide new approaches to the propulsion of manned aircraft by the use of nuclear fission as the power source, thereby overcoming the limitations of range and endurance of chemically-powered aircraft. The ultimate objective being the development of a militarily useful aircraft that could be used for strategic and reconnaissance purposes.

The major components of the nuclear-powered airplane were the propulsion system and the airframe. Five major contractors worked on the ANP program. Propulsion contractors were General Electric Company (GE), Aircraft Nuclear Propulsion Department, and the Pratt & Whitney Aircraft Division of United Aircraft Corporation. Airframe contractors were Convair Division of General Dynamics Corporation, and the Georgia Division of



Lockheed Aircraft Corporation. The Union Carbide Nuclear Company, operator of the Oak Ridge National Laboratory (ORNL) being the major contractor in the general support area.

A number of achievements can be attributed to the 1-billion-dollar ANP program prior to its termination in 1961. Convair successfully flew a functional nuclear reactor in the NB-36H prototype, though the reactor never powered the aircraft in flight. In October 1960, Convair received a contract to proceed with work on the NX-2, an aircraft design that could demonstrate the capabilities of a nuclear-propelled powerplant and GE built the XNJ140E-1 nuclear-powered turbojet and its chemically-powered counterpart, the X211. As part of the advanced applications portion of testing, GE proposed the use of a flying testbed in order to expose the engines to its operational environment well in advance of its use as an actual propulsion system.



The Convair XB-36H 'Crusader' carried a nuclear reactor aboard the aircraft, though it never powered the bomber in flight. Convair photo.

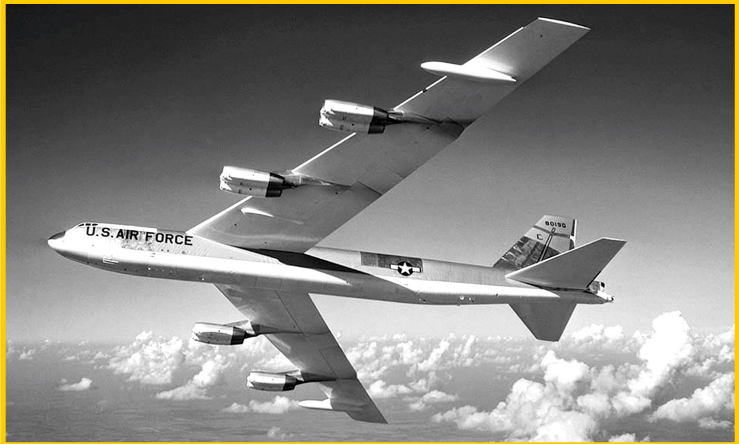

The Boeing B-52G was chosen as the best candidate for the nuclear propulsion testbed over larger cargo aircraft and the Convair B-58 'Hustler'. Boeing photo.

Aircraft evaluated as potential testbeds included the Lockheed C-130 Hercules, Douglas C-133A Cargomaster, Boeing KC-135 Stratotanker, Boeing B-52G Stratofortress and Convair B-58 Hustler.

Of these, the Boeing B-52G was selected since it met the load-carrying and space requirements for testing the XNJ140E-1 powerplant, and its performance characteristics permitted testing under expected NX-2 flight conditions. Three configurations for mounting the test engine were studied, and GE preferred side-mounting the engine to the aft fuselage of the Stratofortress.

The General Electric XNJ140E-1 propulsion unit utilized a single X211 mated to a beryllium oxide reactor with an approximate weight of 60,600 pounds; Basic illustration showing the general layout of the proposed B-52G Stratofortress XNJ140E-1 testbed.

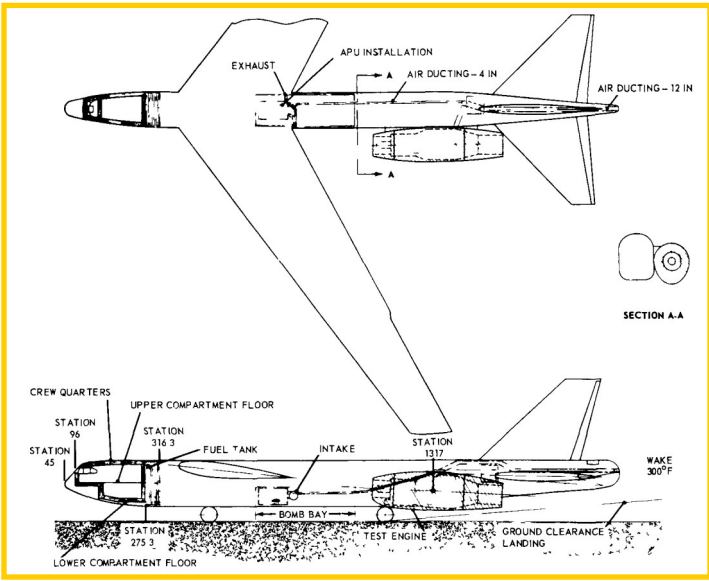

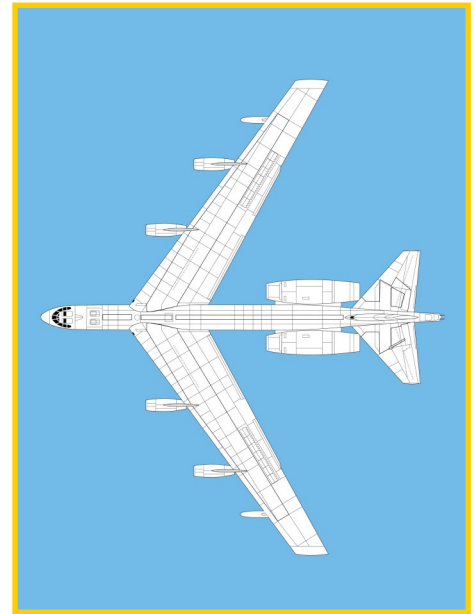
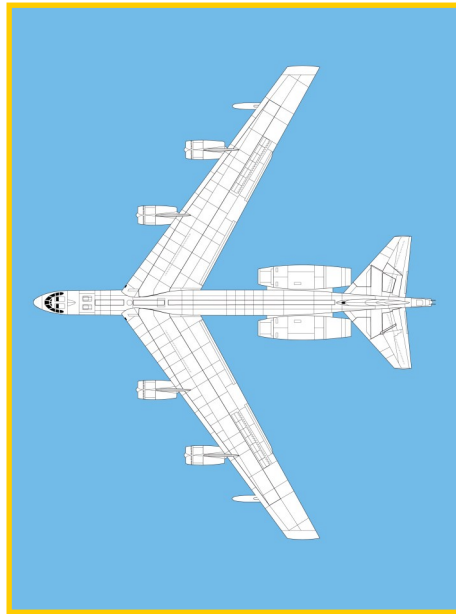
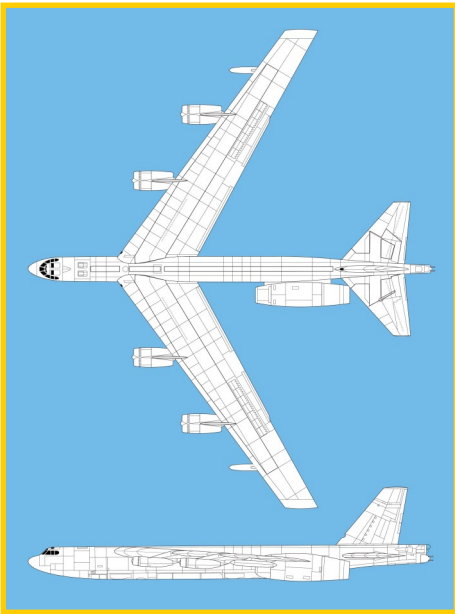

The different proposed test configurations of the B-52G are shown above. A single XNJ140E-1 nuclear powerplant with eight J57 chemically-powered engines (above, left); a single XNJ140E-1 and single X211 chemical-powered variant of the XNJ140E-1 on each side of the aft fuselage with eight J57 engines (above, center); and two XNJ140E-1 nuclear engines with four J57 chemical engines. Illustrations by Author.

18,320 pounds for the turbojet and 42,230 for the reactor, shielding and controls. Formed of 25,000 hexagonal tubes made from yttria-stabilized beryllia containing uranium, the reactor was capable of at least 121 megawatts for takeoff, providing 35,310 pounds of thrust while flying at Mach 0.64 at 25,000 feet with an endurance limited only by the crew radiation dose tolerance. Minimal radiation shielding would be required to specific systems and crew of the B-52G since the entire nuclear propulsion run time was expected be under 1,000 hours.

GE studied the adaptability of the B-52G airframe in three different combinations of nuclear and chemical powerplants. The first study consisted of the chemical Stratofortress modified to include one GE XNJ140E-1 nuclear powerplant while retaining all eight Pratt & Whitney J57 chemical powerplants. This option provided the best safety margin as the B-52G would use the eight J57's for normal flight operations with the nuclear powerplant tested under specific flight conditions.

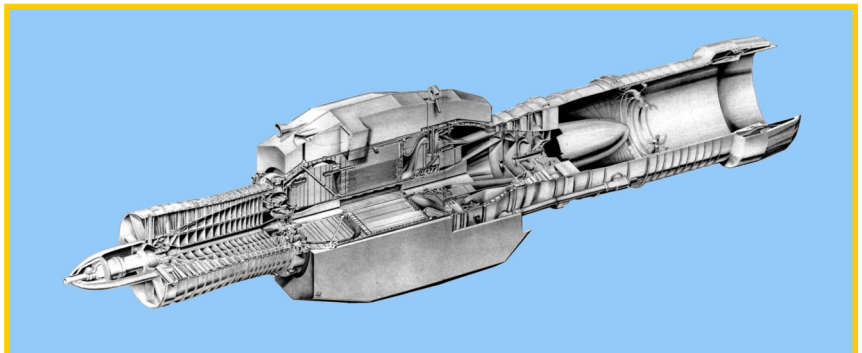
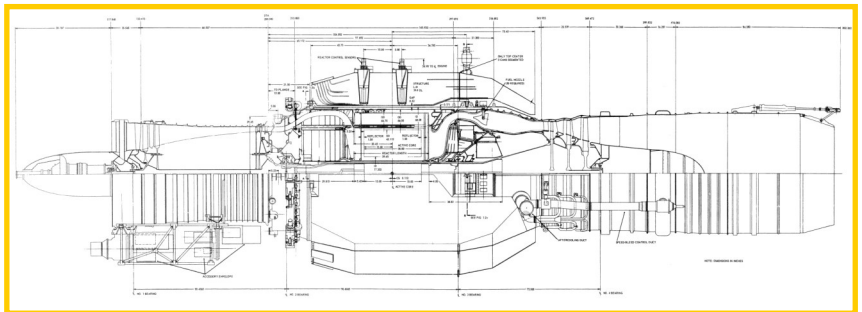

General Electric's XNJ140E-1 nuclear-powerplant shown in the two illustrations above, made use of an X211 mated to a beryllium oxide reactor. The highly-shielded reactor was made up of 25,000 hexagonal tubes made from yttria-stabilized beryllia containing uranium.

The second configuration consisted of the eight J57's with one XNJ140E-1 nuclear-propelled engine mounted on one side and one chemical-powered X211 on the opposite side. The purpose for this test was to compare the nuclear engine to its chemically powered counterpart under take-off and flight conditions.

The third configuration consisted of two XNJ140E-1 nuclear powerplants and four J57 chemical powerplants. The purpose was to explore the feasibility of all-nuclear-powered flight. Retaining four J57's allowed a safety margin during take-off or during single-engine nuclear powerplant inoperability.

Nuclear propulsion was studied during this timeframe for all types of transportation including naval ships and submarines, helicopters, hydrofoils, rockets, and missiles. The complexity, cost and safety concerns eventually precluded the use of nuclear propulsion in all atmospheric flight vehicles. Turbojet engine efficiency and in-flight refueling capabilities replaced the few benefits that could be achieved through nuclear-powered flight.

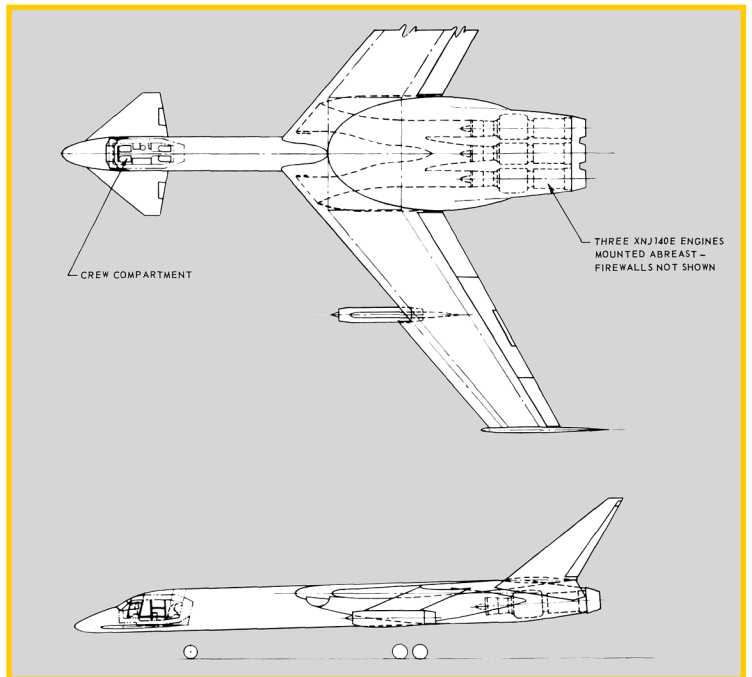
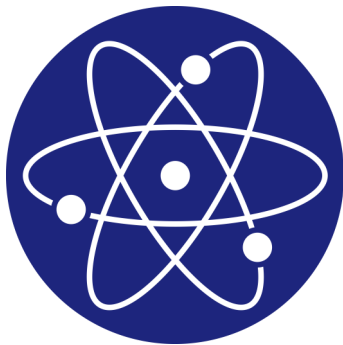

This proposal of Convair's NX-2 nuclear-powered test vehicle shows three of the nuclear turbojets mounted in aft fuselage with a single chemical-powered engine mounted under each wing.

Further reading: Review of Manned Nuclear Propulsion Program, Atomic Energy Commission and Department of Defense; Comptroller General of the United States; February 1963

APEX-910; Aircraft Nuclear Propulsion Application Studies; General Electric, Flight Propulsion Laboratory Department; April 1962

History in Two: Manned Nuclear Aircraft Program; Jack Waid, AFMC History Office; June 2021



AFMC History & Museums Program

HQ AFMC/HO

4225 Logistics Ave, RM S133 - Wright-Patterson AFB 45433-5006 - DSN: 713-1797 - Comm: (937) 713-1797

For general inquiries, archives, and/or research questions, contact: R. Ray Ortensie

For heritage and exhibit questions, contact: Jack Waid

HQAFMC.HO@us.af.mil